

# Ansys 2025/R2

POWERING INNOVATION THAT DRIVES HUMAN ADVANCEMENT

© 2025 ANSYS, Inc. or its affiliated companies  
Unauthorized use, distribution, or duplication is prohibited.

## Getting Started with Icepak®: Coil and Plate



ANSYS, Inc.  
Southpointe  
2600 Ansys Drive  
Canonsburg, PA 15317  
[ansysinfo@ansys.com](mailto:ansysinfo@ansys.com)  
<https://www.ansys.com>  
(T) 724-746-3304  
(F) 724-514-9494

Release 2025 R2  
July 2025

ANSYS, Inc. and  
ANSYS Europe,  
Ltd. are UL  
registered ISO  
9001:2015 com-  
panies.

## Copyright and Trademark Information

© 1986-2025 ANSYS, Inc. Unauthorized use, distribution or duplication is prohibited.

ANSYS, Ansys Workbench, AUTODYN, CFX, FLUENT and any and all ANSYS, Inc. brand, product, service and feature names, logos and slogans are registered trademarks or trademarks of ANSYS, Inc. or its subsidiaries located in the United States or other countries. Icem CFD is a trademark used by ANSYS, Inc. under license. All other brand, product, service and feature names or trademarks are the property of their respective owners. FLEXIm and FLEXnet are trademarks of Flexera Software LLC.

## Disclaimer Notice

THIS ANSYS SOFTWARE PRODUCT AND PROGRAM DOCUMENTATION INCLUDE TRADE SECRETS AND ARE CONFIDENTIAL AND PROPRIETARY PRODUCTS OF ANSYS, INC., ITS SUBSIDIARIES, OR LICENSORS. The software products and documentation are furnished by ANSYS, Inc., its subsidiaries, or affiliates under a software license agreement that contains provisions concerning non-disclosure, copying, length and nature of use, compliance with exporting laws, warranties, disclaimers, limitations of liability, and remedies, and other provisions. The software products and documentation may be used, disclosed, transferred, or copied only in accordance with the terms and conditions of that software license agreement.

ANSYS, Inc. and ANSYS Europe, Ltd. are UL registered ISO 9001: 2015 companies.

## U.S. Government Rights

For U.S. Government users, except as specifically granted by the ANSYS, Inc. software license agreement, the use, duplication, or disclosure by the United States Government is subject to restrictions stated in the ANSYS, Inc. software license agreement and FAR 12.212 (for non-DOD licenses).

## Third-Party Software

See the legal information in the product help files for the complete Legal Notice for Ansys proprietary software and third-party software. If you are unable to access the Legal Notice, please contact ANSYS, Inc.

## Conventions Used in this Guide

Please take a moment to review how instructions and other useful information are presented in this documentation.

- Procedures are presented as numbered lists. A single bullet indicates that the procedure has only one step.
- Bold type is used for the following:
  - Keyboard entries that should be typed in their entirety exactly as shown. For example, “**copy file1**” means you must type the word **copy**, then type a space, and then type **file1**.
  - On-screen prompts and messages, names of options and text boxes, and menu commands. Menu commands are often separated by greater than signs (>). For example, “click **HFSS > Excitations > Assign > Wave Port.**”
  - Labeled keys on the computer keyboard. For example, “Press **Enter**” means to press the key labeled **Enter**.
- Italic type is used for the following:
  - Emphasis.
  - The titles of publications.
  - Keyboard entries when a name or a variable must be typed in place of the words in italics. For example, “**copy filename**” means you must type the word **copy**, then type a space, and then type the name of the file.
- The plus sign (+) is used between keyboard keys to indicate that you should press the keys at the same time. For example, “Press Shift+F1” means to press the **Shift** key and, while holding it down, press the **F1** key also. You should always depress the modifier key or keys first (for example, Shift, Ctrl, Alt, or Ctrl+Shift), continue to hold it/them down, and then press the last key in the instruction.

**Accessing Commands:** *Ribbons*, *menu bars*, and *shortcut menus* are three methods that can be used to see what commands are available in the application.

- The *Ribbon* occupies the rectangular area at the top of the application window and contains multiple tabs. Each tab has relevant commands that are organized, grouped, and labeled. An example of a typical user interaction is as follows:

"Click **Draw > Line**"



This instruction means that you should click the **Line** command on the **Draw** ribbon tab. An image of the command icon, or a partial view of the ribbon, is often included with the instruction.

- The *menu bar* (located above the ribbon) is a group of the main commands of an application arranged by category such File, Edit, View, Project, etc. An example of a typical user interaction is as follows:

"On the **File** menu, click the **Open Examples** command" means you can click the **File** menu and then click **Open Examples** to launch the dialog box.

- Another alternative is to use the *shortcut menu* that appears when you click the right-mouse button. An example of a typical user interaction is as follows:

"Right-click and select **Assign Excitation> Wave Port**" means when you click the right-mouse button with an object face selected, you can execute the excitation commands from the shortcut menu (and the corresponding sub-menus).

### Getting Help: Ansys Technical Support

For information about Ansys Technical Support, go to the Ansys corporate Support website, <http://www.ansys.com/Support>. You can also contact your Ansys account manager in order to obtain this information.

All Ansys software files are ASCII text and can be sent conveniently by e-mail. When reporting difficulties, it is extremely helpful to include very specific information about what steps were taken or what stages the simulation reached, including software files as applicable. This allows more rapid and effective debugging.

### Help Menu

To access help from the Help menu, click **Help** and select from the menu:

- **[product name] Help** - opens the contents of the help. This help includes the help for the product and its *Getting Started Guides*.
- **[product name] Scripting Help** - opens the contents of the *Scripting Guide*.
- **[product name] Getting Started Guides** - opens a topic that contains links to Getting Started Guides in the help system.

### Context-Sensitive Help

To access help from the user interface, press **F1**. The help specific to the active product (design type) opens.

You can press **F1** while the cursor is pointing at a menu command or while a particular dialog box or dialog box tab is open. In this case, the help page associated with the command or open dialog box is displayed automatically.

# Table of Contents

<b>Table of Contents</b> .....	<b>Contents-1</b>
<b>1 - Introduction</b> .....	<b>1-1</b>
<b>2 - Run the Maxwell Simulation</b> .....	<b>2-1</b>
Open the Project .....	2-1
Launch the Ansys Electronics Desktop .....	2-1
Set 3D UI Options .....	2-1
Open the Project .....	2-2
Review the Maxwell Design .....	2-3
Analyze the Design and Report EM Losses .....	2-5
<b>3 - Prepare and Run the Icepak Simulation</b> .....	<b>3-1</b>
Set Up the Icepak Design .....	3-1
Assign Thermal Boundary Conditions .....	3-5
Assign an Opening .....	3-5
Assign the EM Volume Loss .....	3-6
Create a Face Monitor .....	3-7
Set Solution Type .....	3-8
Define Icepak Design Settings .....	3-9
Add a Solution Setup .....	3-10
Generate a Global Mesh .....	3-15
View Global Mesh Settings .....	3-15
Create a Mesh Operation .....	3-16
Generate and Examine the Mesh .....	3-17
Run the Icepak Simulation .....	3-17
<b>4 - Postprocess the Icepak Simulation</b> .....	<b>4-1</b>
Create Field Plots .....	4-1
Create a Temperature Field Plot .....	4-1
Create a Plane .....	4-2
Create a Velocity Vector Plot .....	4-3

---

Create a Fields Summary ..... 4-4

# 1 - Introduction

This document is intended as supplementary material to Icepak for beginners and advanced users. It includes instructions to assign an excitation in a Maxwell design and create and solve an Icepak design based on the same geometry.

This chapter contains the following topic:

- "Sample Project - The Coil and Plate" below

## Sample Project - The Coil and Plate

In this project, you will learn how to perform Maxwell to Icepak coupling. Maxwell calculates the EM losses, and Icepak solves for thermal fields.

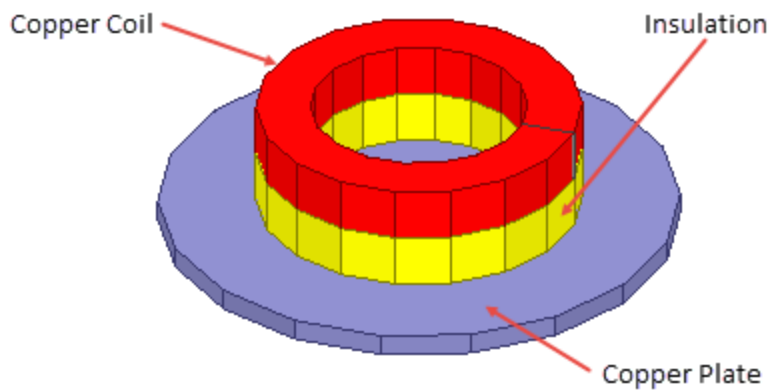

**Figure 1-1: Coil and Plate**



## 2 - Run the Maxwell Simulation

This chapter contains the following topics:

- [Open the Project](#)
- [Review the Maxwell Design](#)
- [Analyze the Maxwell Design and Report Losses](#)

### Open the Project

This chapter contains the following topics:

- Launch the Ansys Electronics Desktop

### Launch the Ansys Electronics Desktop

A shortcut of the Ansys Electronics Desktop application appears on your desktop once the application is installed.

### Set 3D UI Options

Ensure that the new view orientation scheme introduced in release 2024 R1 is not being used, since the instructions and images in this guide are based on the legacy orientation scheme.

1. From the menu bar, click **View > Options**.

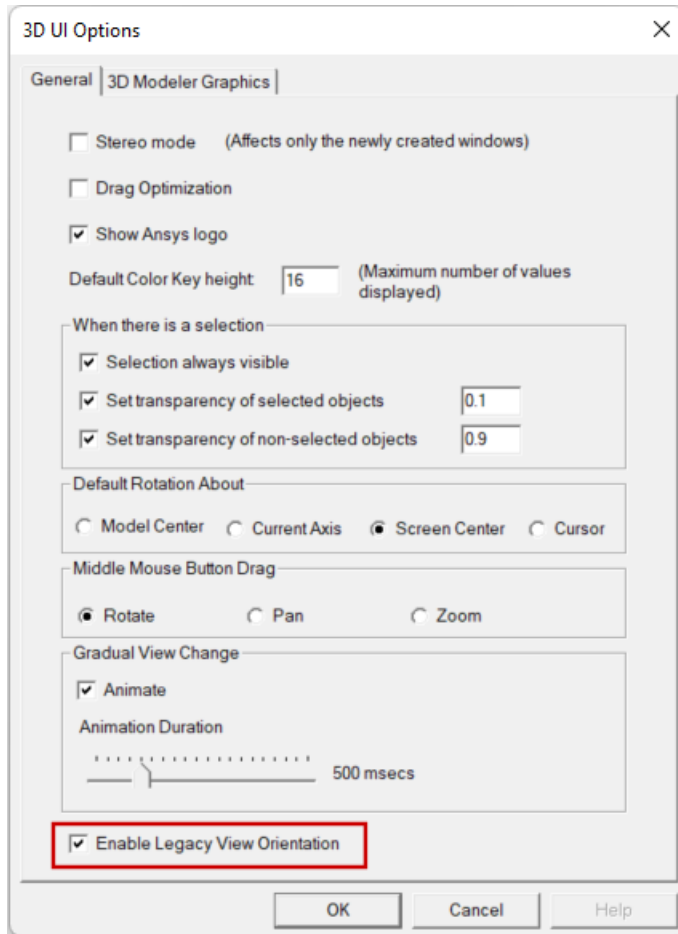

The *3D UI Options* dialog box appears.

2. Ensure that **Enable Legacy View Orientation** is enabled:



3. Click **OK**.

## Open the Project

1. On the **Desktop** ribbon tab, click  **Open Examples**. Then:
  - a. In the *Open* dialog box that appears, click the parent folder icon () once to move up one level above the *Examples* folder.
  - b. Double-click the **Help** folder and then the **Icepak** folder.
  - c. Select the file **Coil\_Plate\_Maxwell.aedt** and click **Open**.
2. The model is displayed in the **3D Modeler** window.

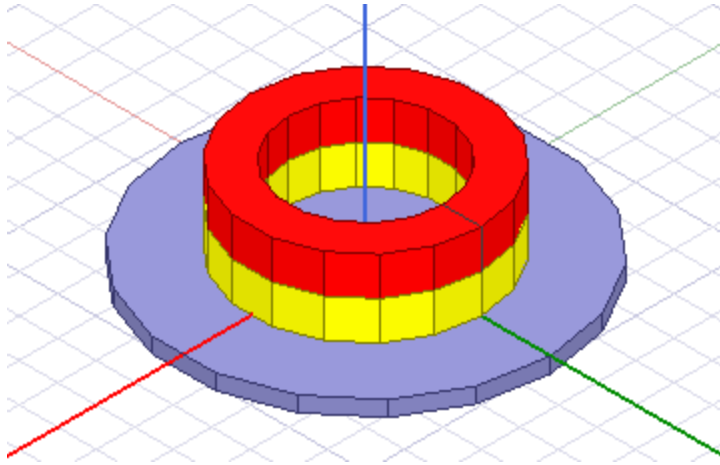
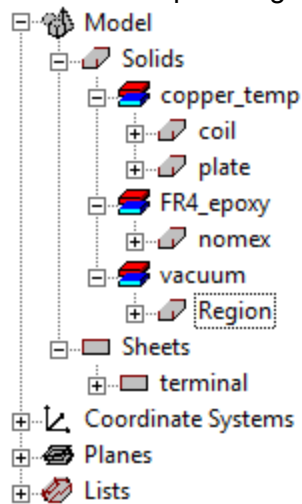

**Figure 2-1: Coil and copper plate model in the 3D Modeler window**

3. From the **File** menu, select **Save As**, and save the project in the desired working directory.

## Review the Maxwell Design

1. In the history tree, expand **Model > Solids > copper\_temp**, **FR4\_epoxy**, and **vacuum** and review the component geometry.



**Figure 2-2: History tree**

**Note:** The coil and plate material assignment is copper\_temp, and the insulation is set to FR4\_epoxy. Right-click on a material and select Properties to view a material's various properties.

2. From the **Maxwell 3D** menu, select **Solution Type**. Note that the solution type is set to **Eddy Current** and click **OK**.

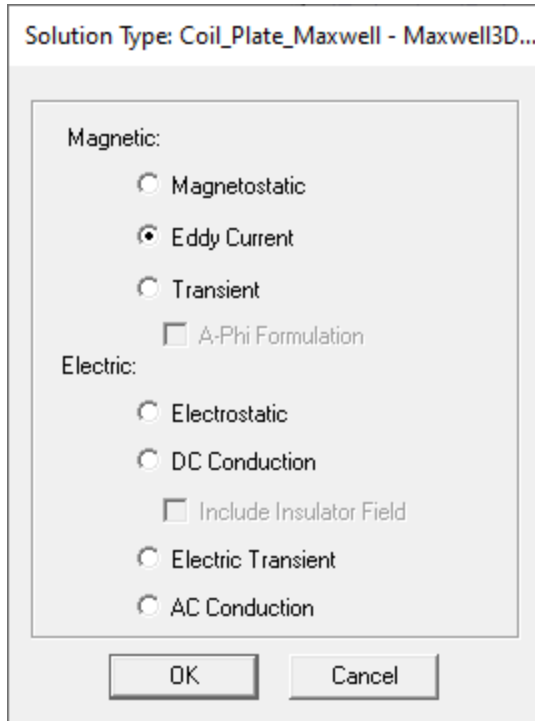

Figure 2-3: Solution Type dialog box

3. In the **Project Manager**, expand **Excitations** and select **Current1**.
4. In the **Properties** window, note the **Evaluated Value**.

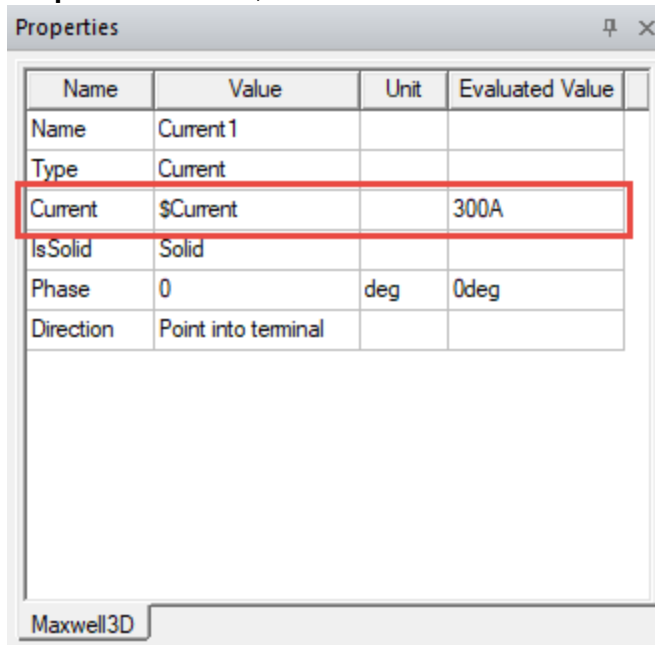

Figure 2-4: Properties window - Current1

## Analyze the Design and Report EM Losses

1. In the **Project Manager**, expand **Analysis**.
2. Right-click on the solution setup (*Setup1*) and select **Analyze** to run the Maxwell simulation.
3. Right-click Setup1 and select **Convergence**.
4. Change the **View** to **Plot** and, from the **Y:** drop-down list, select **Energy Error [%]**.

**Note:** When the simulation is complete, a message is displayed in the **Message Manager** indicating normal completion.

5. After the simulation is complete and you're finished reviewing the convergence plot, click **Close**.
6. From the **Maxwell 3D** menu, select **Fields > Calculator** to open the **Fields Calculator**.
7. Under **Input**, click **Quantity** and select **EMLoss**.
8. Click **Geometry**, select **Volume**, select **AllObjects**, and click **OK**.
9. Under **Scalar**, click **Integrate** ( $\int$ ).
10. Under **Output**, click **Eval**. The EM loss is calculated.

**Note:** The EM loss is displayed in Watts.

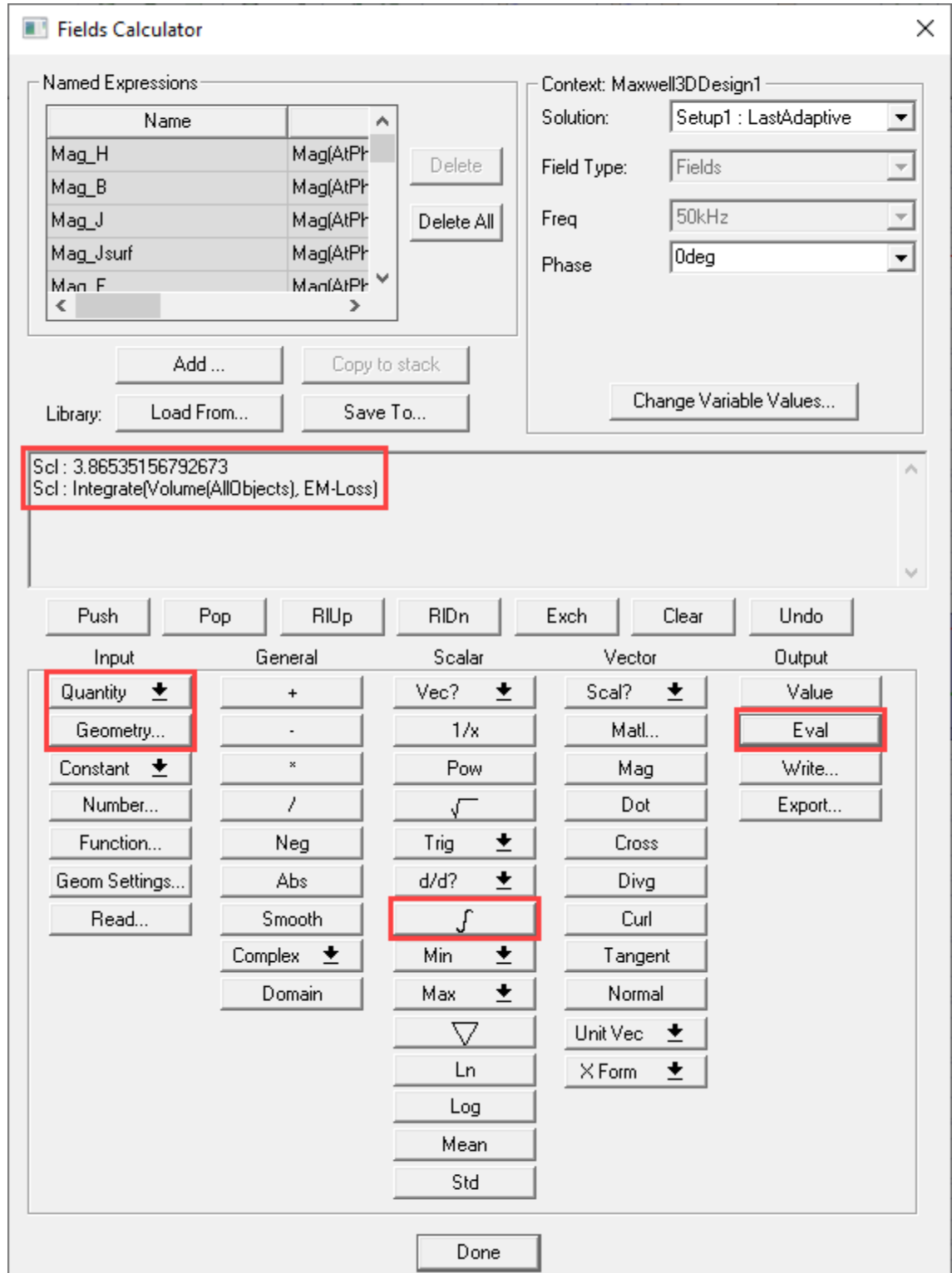

Figure 2-5: Fields Calculator

11. Confirm the EM loss, and click **Done** to close the **Fields Calculator**.

12. From the **File** menu, select **Save**.



# 3 - Prepare and Run the Icepak Simulation

This chapter contains the following topics:

- [Set Up the Icepak Design](#)
- [Assign Thermal Boundary Conditions](#)
- [Set Solution Type](#)
- [Define Design Settings](#)
- [Add a Solution Setup](#)
- [Generate a Global Mesh](#)
- [Run the Icepak Simulation](#)

## Set Up the Icepak Design

1. In the history tree, right-click **Model** and select **Select All**.

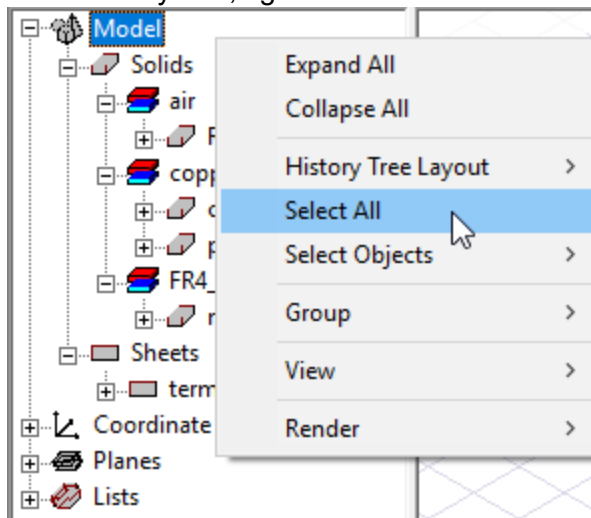

**Figure 3-1: History Tree**

2. From the **Edit** menu, select **Copy** to copy all of the geometry and material information. Alternatively, you can press **Ctrl + C** to copy the geometry.
3. On the **Desktop** ribbon, click **Icepak**.

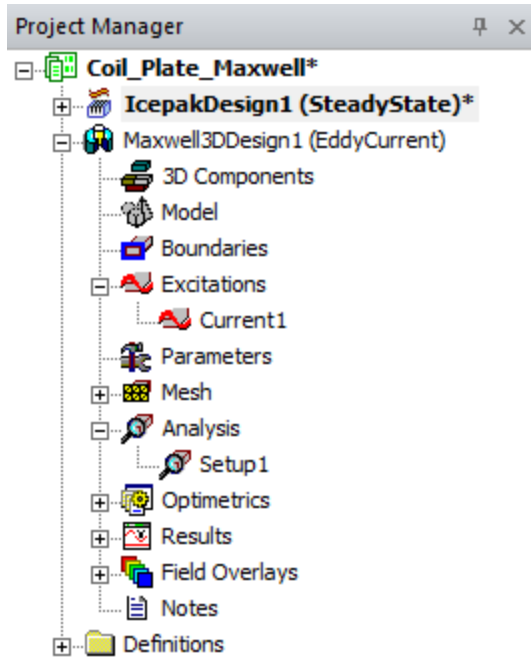

Figure 3-2: Project Manager

4. Right-click in the **3D Modeler** window and select **Edit > Paste**. The geometry from the Maxwell design is inserted into the Icepak design. Alternatively, you can press **Ctrl + V** to paste the geometry.
5. On the **Draw** ribbon, click **Fit All**. Alternatively, you can press **Ctrl + D** to fit the geometry.

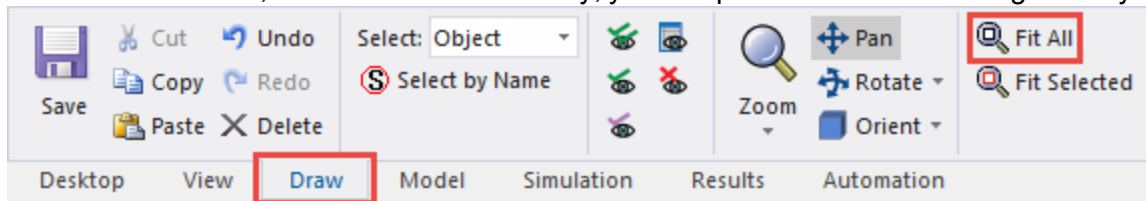
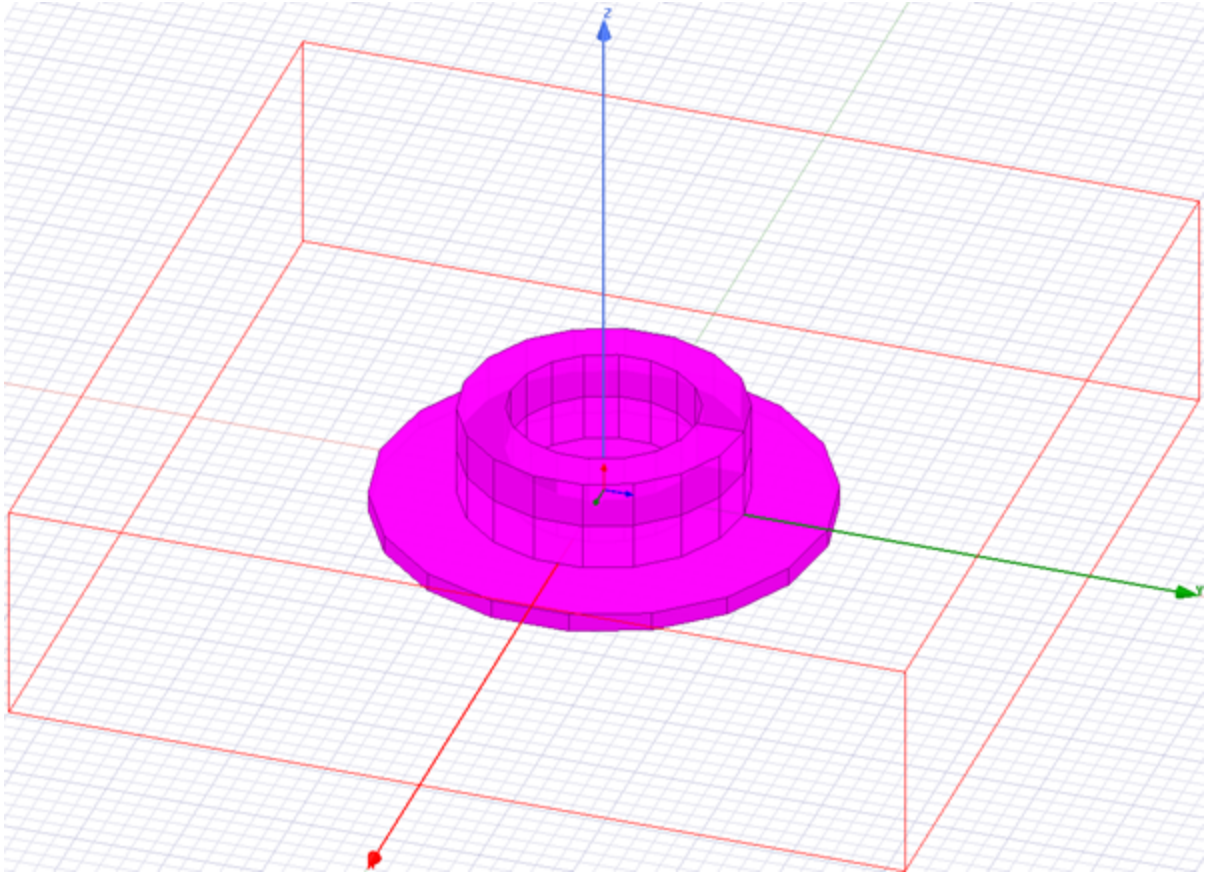

Figure 3-3: Draw ribbon - Fit All



**Figure 3-4: Coil and Plate Geometry in Icepak Design**

**Note:** The **Region** geometry (computational domain) is automatically created.

6. In the history tree, expand **Model > Solids > Air > Region** and select **CreateRegion**.
7. In the **Properties** dialog box, edit the **Value** for **-Z Padding Data** and then **+Z Padding Data** as shown in the following figure to expand the computational domain in the direction of gravity for natural convection analysis.

**Note:**

Ensure that you enter padding values for **-Z Padding Data** before **+Z Padding Data**.

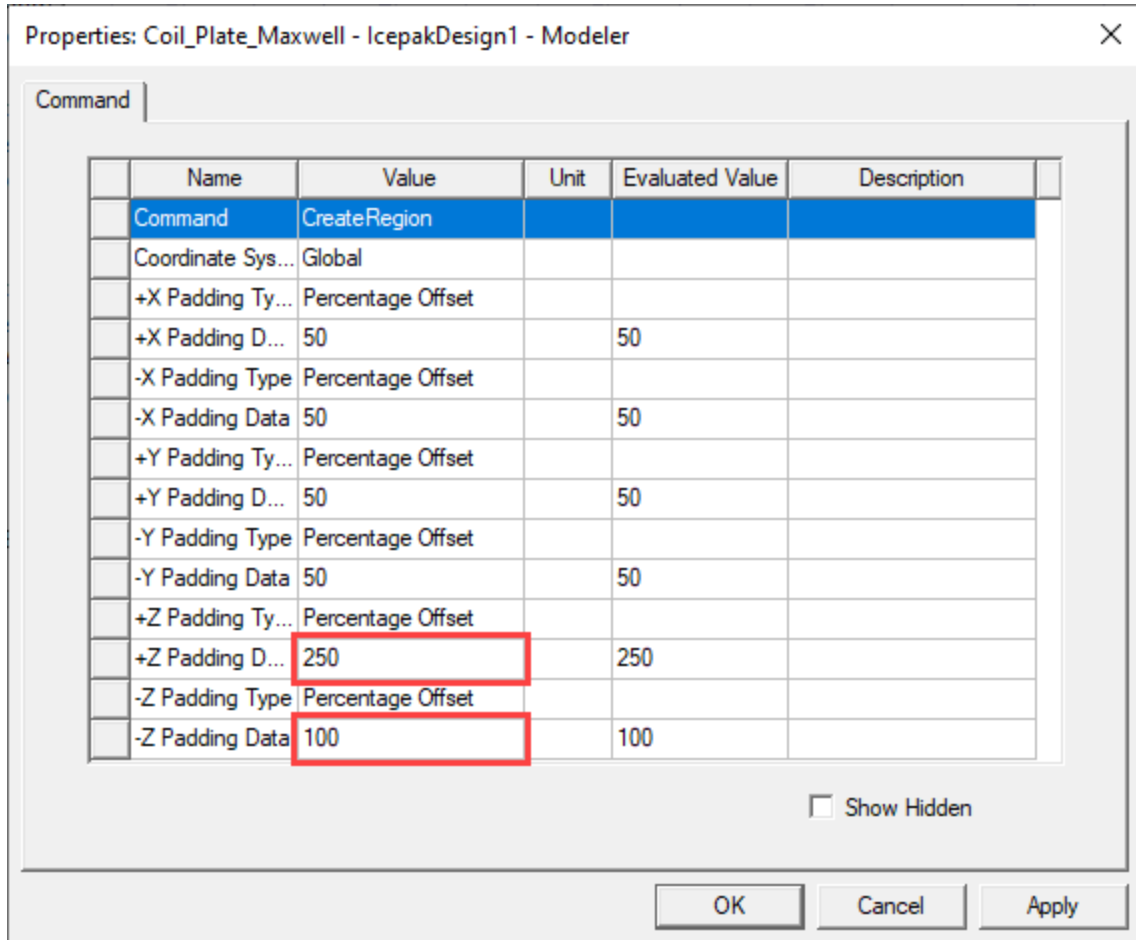

**Figure 3-5: Properties window - CreateRegion**

8. Click **OK** to apply the changes and close the dialog box.
9. In the history tree, right-click *copper\_temp* and select **Properties** to examine the thermal material properties.
10. After reviewing the properties, click **OK**.

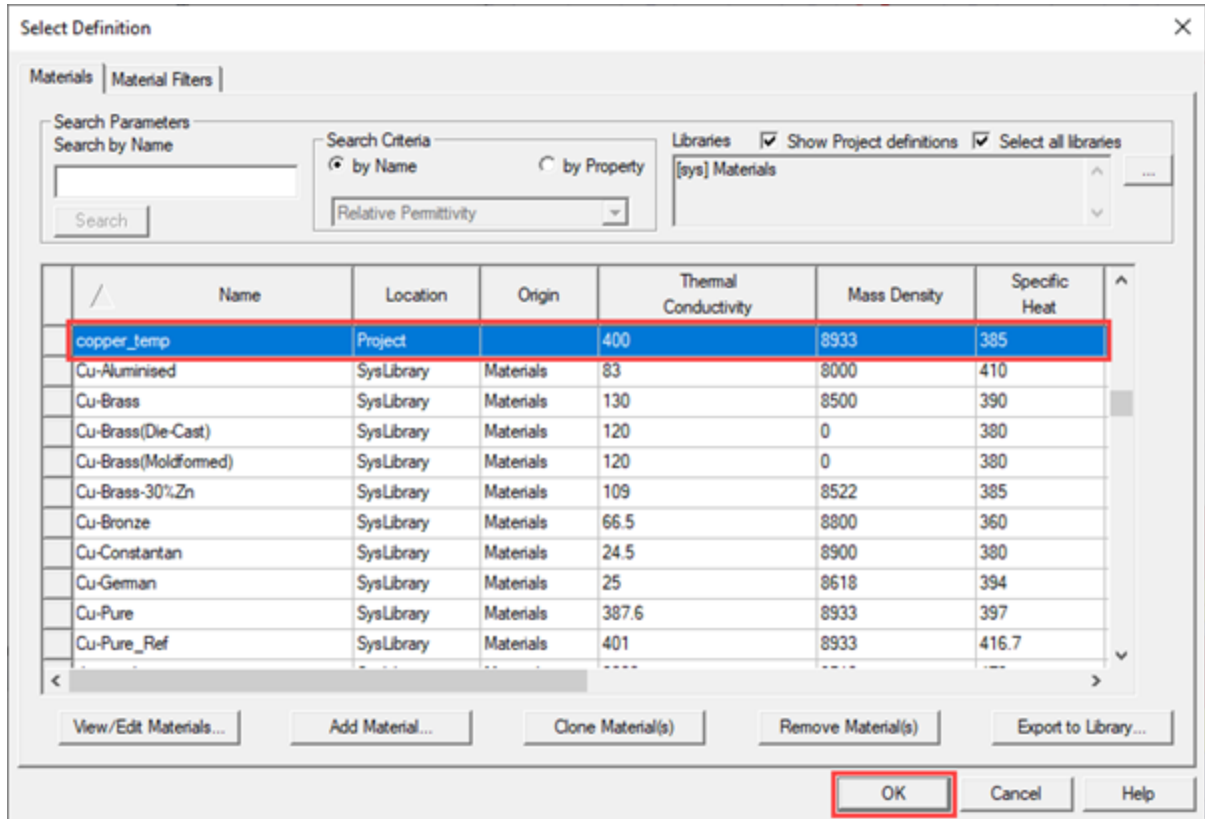

Figure 3-6: Select Definition dialog box

## Assign Thermal Boundary Conditions

### Assign an Opening

1. Press F to enter face selection mode.
2. In the **3D Modeler** window select all six sides of the Region geometry.

**Note:** Use the middle mouse button or the control key and the **Rotate** tool on the **Draw** ribbon to select all six faces.

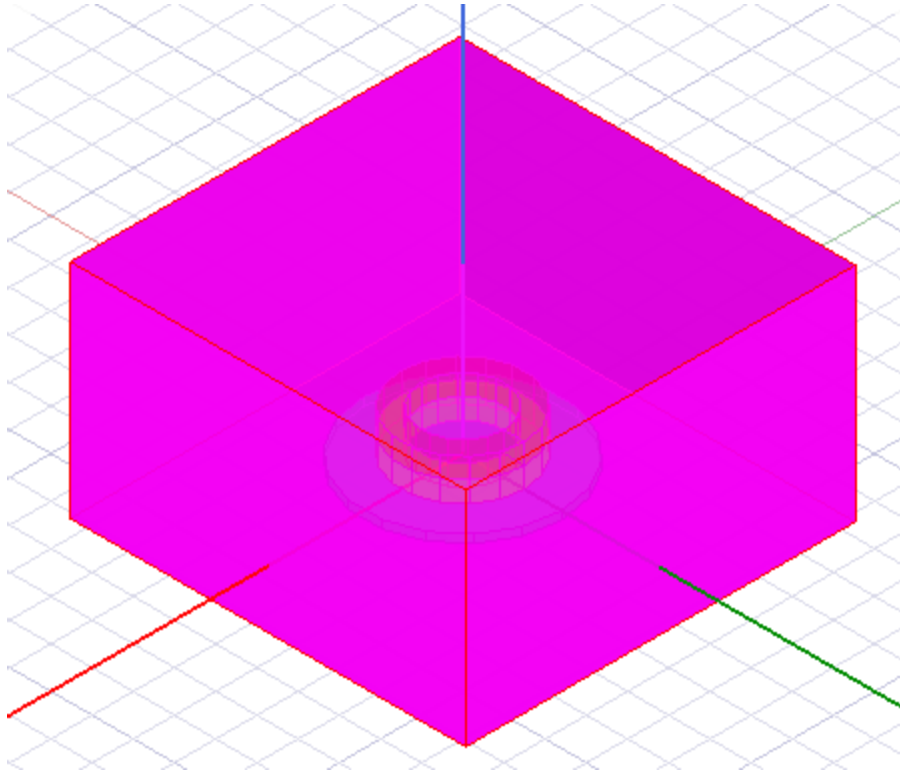
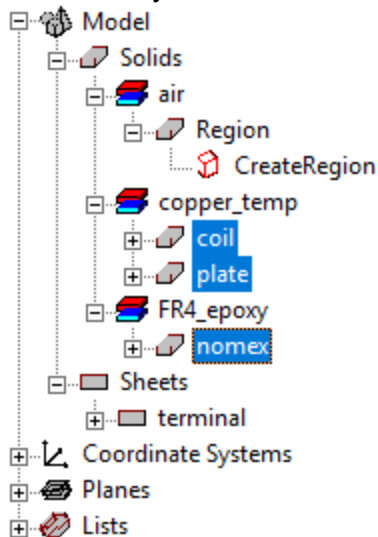

Figure 3-7: Sides of Region geometry

3. Right-click in the **3D Modeler** window and select **Assign Thermal > Free > Opening**.
4. In the **Opening Thermal Model** dialog box, retain the default settings and click **OK**.

## Assign the EM Volume Loss

1. In the history tree, select *coil*, *plate*, and *nomex* using the control key.



**Figure 3-8: History tree - EM loss selection**

2. Right-click in the **3D Modeler** window and select **Assign Thermal > EM Loss**.
3. In the **Setup Link** dialog box, select the **Use This Project** check box.
4. On the **Variable Mapping** tab, click **Map Variable by Name** to compare the source design variables to the Icepak design variables. Any variables with the same name are mapped so that the source design conforms to the Icepak design.
5. Click **OK**.
6. In the **EM Loss** dialog box, enter *VolumeLoss* as the **Name**.
7. Ensure the *coil*, *plate*, and *nomex* are listed under **Volume**. If they are not, drag them under **Volume** to designate a volume loss.
8. Click **OK**.

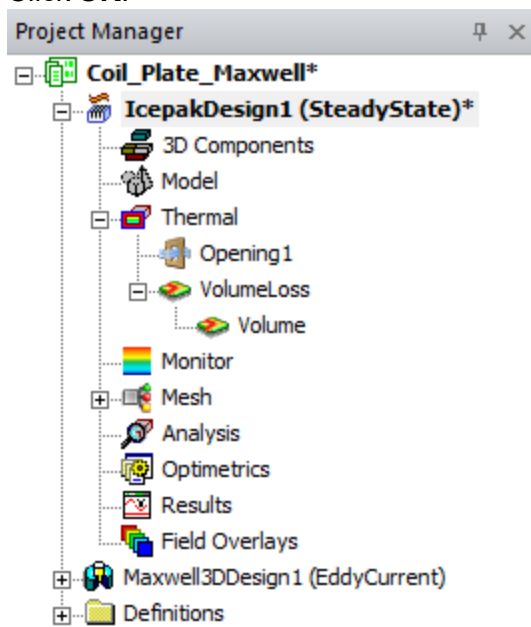
**Figure 3-9: Project Manager - Thermal Boundary Conditions**

9. From the **File** menu, select **Save**.

## Create a Face Monitor

To check the temperature of a specified face during a solution, create a monitor surface and assign a face monitor to it.

1. Press **F** to enter face selection mode.
2. In the **3D Modeler** window, select and right-click the top surface of the coil.

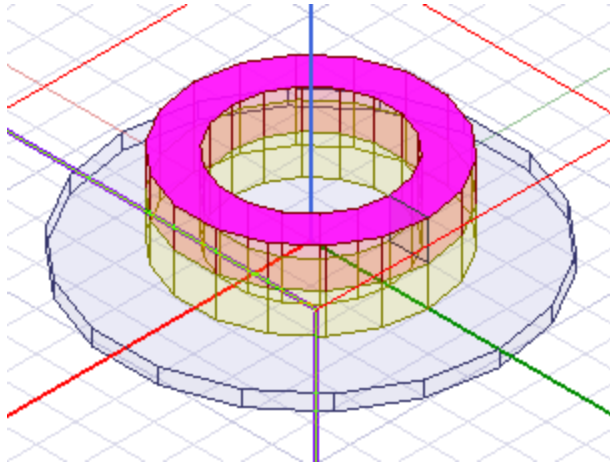

Figure 3-10: Face Selection

3. From the right-click menu, select **Assign Monitor > Face**.
4. In the **Monitor Setup** dialog box, select **Temperature** and click **OK**. The face monitor appears under **Monitor** in the **Project Manager**.

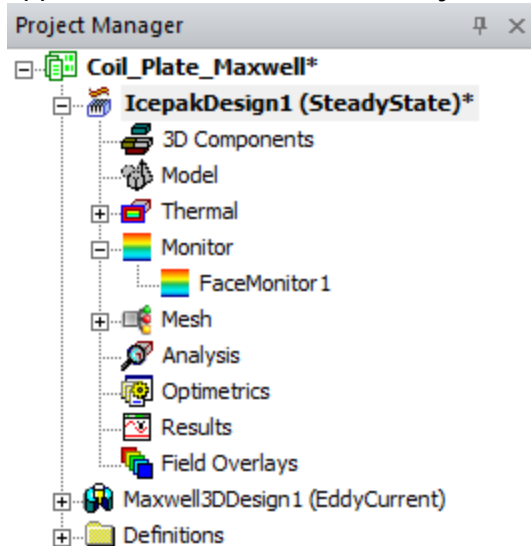

Figure 3-11: Project Manager - Monitor

## Set Solution Type

Specify the design's solution type as follows:

1. Click **Icepak>Solution Type**.  
The **Solution Type** dialog box appears.
2. Ensure that **Steady State** and **Temperature and Flow** are selected and click **OK**.

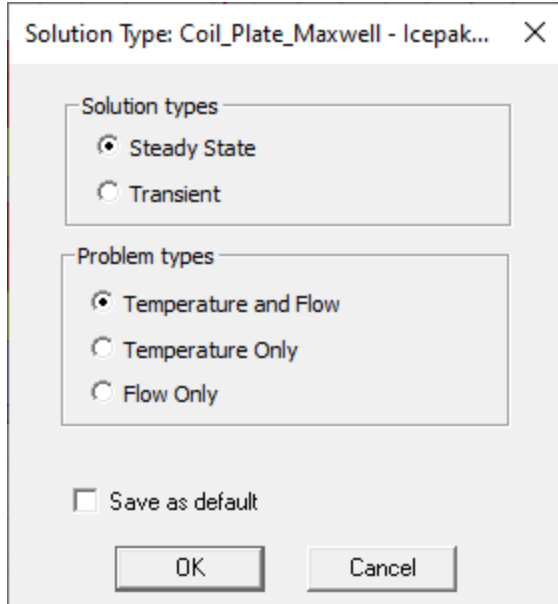

Figure 3-12: Solution Type

## Define Icepak Design Settings

Specify the project design settings as follows:

1. Click **Icepak>Design Settings**.
2. On the **Gravity** tab, ensure the **Gravity Vector** is set to **Global::Z** and **Negative** as shown in the following figure.

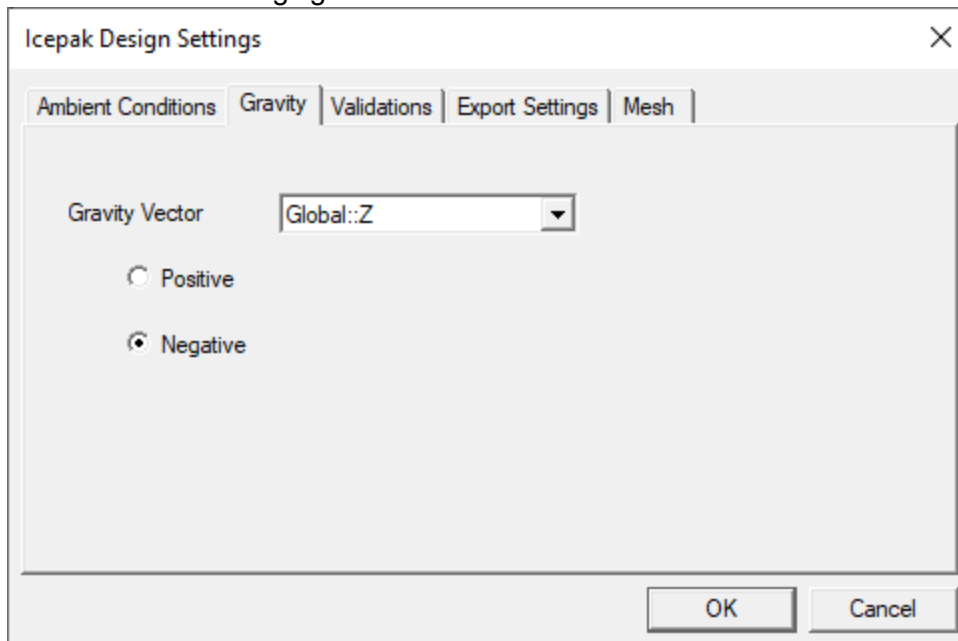

Figure 3-13: Icepak Design Settings dialog box

3. Retain the default settings on the other tabs and click **OK**.

## Add a Solution Setup

Create a solution setup, in which you specify general and advanced solution settings.

1. In the **Project Manager**, right-click on **Analysis** and select **Add Solution Setup**.
2. On the **Icepak Solve Setup Dialog General** tab:
  - For **Maximum Number of Iterations**, enter 300.
  - Under **Flow Regime**, retain the default selection of **Laminar**.
  - Under **Radiation Model**, select **Discrete Ordinates**.
  - Select **Include Gravity**.

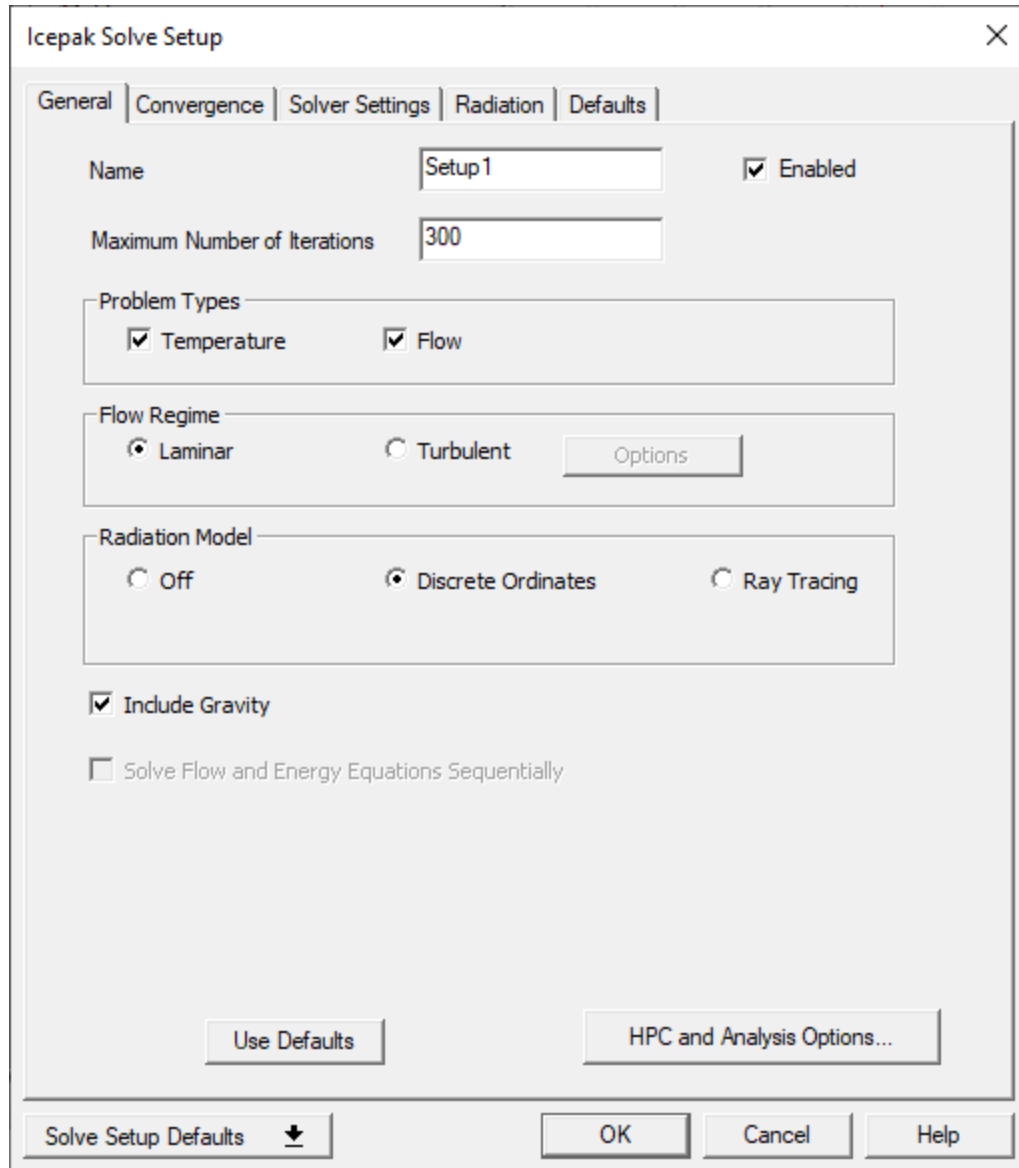

Figure 3-14: Icepak Solve Setup Dialog - General tab

3. On the **Solver Settings** tab:
  - Under **Initial Conditions**, enter 0.001 as the **Z Velocity** and retain the unit **m\_per\_sec**. Generally, if you solve a natural convection problem, the initial condition should be a small value in the opposite direction of gravity because the force driving the flow is weak to proceed with the calculation.
  - Click **Advanced Options**.
4. In the **Advanced Solver Settings** dialog box:
  - For **Pressure**, enter 0.7 for **Under-relaxation** and select **Body Force** for **Discretization Scheme**.

**Note:**

Adjust under-relaxation factors in advance because a calculation tends to be unstable in case of natural convection.

- For **Momentum**, enter 0.3 for **Under-relaxation**.
- Retain the default **Linear Solver Options** and click **OK**.

Advanced Solver Settings

	Under-relaxation	Discretization Scheme	
Pressure	0.7	Body Force	
Momentum	0.3	First	
Temperature	1	First	<input type="checkbox"/> Secondary Gradient
Turbulent Kinetic Energy	0.8	First	
Turbulent Dissipation Rate	0.8	First	
Specific Dissipation Rate	0.8	First	
Discrete Ordinates		First	
Joule Heating	1		

Linear Solver Options

	Type	Termination Criterion	Residual Reduction Tolerance	Stabilization
Pressure	V	0.1	0.1	None
Momentum	flex	0.1	0.1	
Temperature	F	0.1	0.1	None
Turbulent Kinetic Energy	flex	0.1	0.1	
Turbulent Dissipation Rate	flex	0.1	0.1	
Specific Dissipation Rate	flex	0.1	0.1	
Joule Heating	F	1e-09	1e-09	None
Maximum Cycles	30			

Coupled pressure-velocity formulation

2D profile interpolation method: Inverse Distance Weighted

Use Defaults

OK Cancel

Figure 3-15: Advanced Solver Settings

5. On the **Radiation** tab:

- Under **Iteration Parameters**, enter 5 for **Flow Iterations per Radiation Iteration**.
- Under **Angular Discretization**, enter 2 for **Theta Divisions**, **Phi Divisions**, **Theta Pixels**, and **Phi Pixels**.

**Note:** For coarse models without angled faces, a value of 1 is acceptable, and for fine models with angled faces, a value of 2 or 3 should be used. Note that increasing the angular discretization has a large impact on overall CPU time.

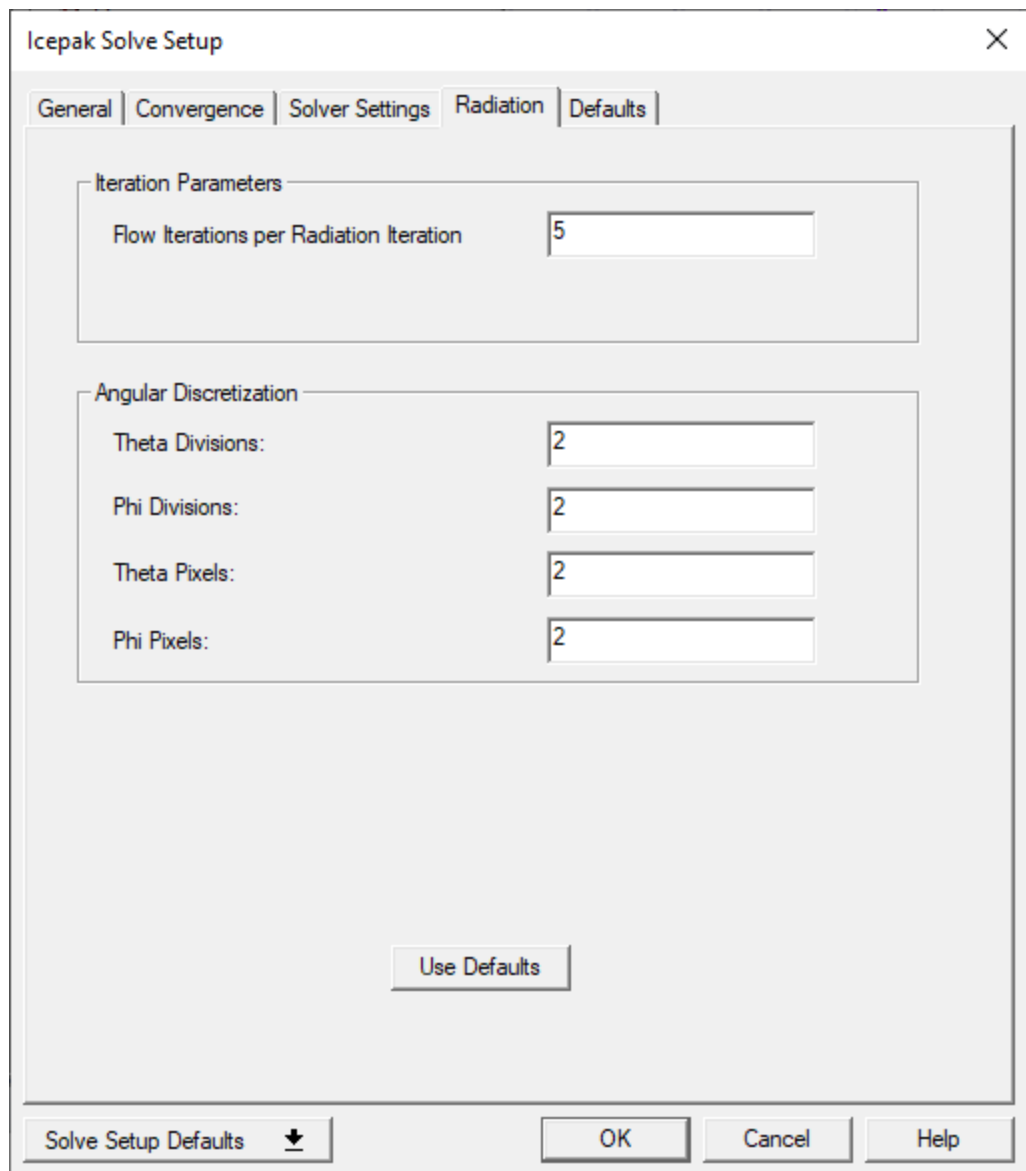

**Figure 3-16: Icepak Solve Setup Dialog - Radiation tab**

6. Click **OK** to save the settings. The solution setup is added under **Analysis** in the **Project Manager**.
7. From the **File** menu, click **Save**.

## Generate a Global Mesh

When the model geometry is finished, you can mesh the model. In this example, you'll create a global mesh using the advanced mesh settings.

### View Global Mesh Settings

1. In the **Project Manager**, right-click on **Mesh** and select **Edit Global Region**.
2. In the **Mesh Region** dialog box, retain the default settings on the **General** tab.
3. On the **Advanced** tab select **User specified** and edit the following settings:
  - Under **Maximum Element Size**, enter 2 mm for **X**, **Y**, and **Z**.
  - Under **Minimum Gap**, enter 0.1 mm for **X**, **Y**, and **Z**.
  - Under **Multi-level meshing**, select **Enable** and enter 2 for **Max Levels** and 1 for **Buffer Layers**.

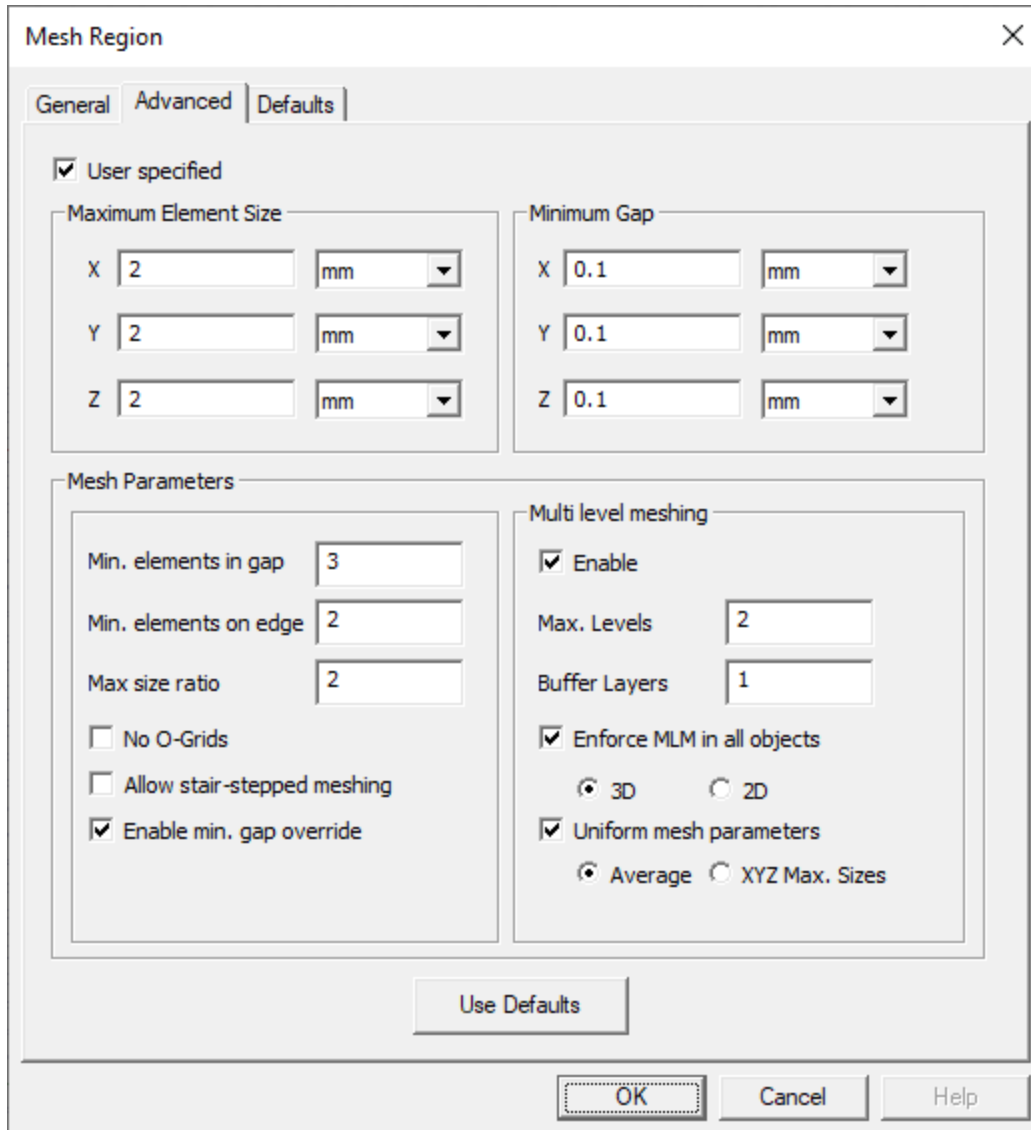

Figure 3-17: Mesh Region dialog box - Advanced tab

4. Click **OK**.

## Create a Mesh Operation

Create a mesh operation to specify a division level for the selected objects. The mesh operation setting allows to uniform the mesh size of the surface.

1. In the history tree, select *coil*, *plate*, and *nomex*.
2. Right-click and select **Assign Mesh Operation**.
3. In the **Mesh Operation** dialog box under **Level**, enter 2 for **Max**.
4. Click **OK**.

## Generate and Examine the Mesh

1. On the **Simulation** ribbon, click **Generate Mesh**. When the mesh operation is complete, the mesh loads and the **Mesh visualization** dialog box appears.
2. In the **Mesh visualization** dialog box under **Mesh display on**, select **Geometry/Boundary selection**.
3. In the history tree, select *coil*, *plate*, and *nomex* to display the mesh for the selected objects.
4. On the **View** ribbon, click the **Isometric** orientation option  from the **Orient** drop-down list.

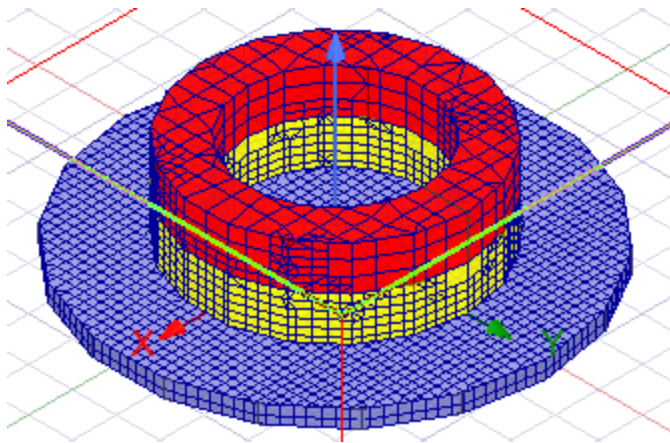

**Figure 3-18: Global Mesh**

5. In the **Mesh visualization** dialog box, click the **Quality** tab and toggle between **Face alignment**, **Volume**, and **Skewness**, noting the **Min** value and **Max** value for each.

**Note:** The following are targets value for face alignment and skewness that increase the probability of simulation convergence and accurate results.

- Face alignment: >0.05
  - Skewness: >0.02
6. Click **Close** to close the **Mesh visualization** dialog box.

## Run the Icepak Simulation

1. In the **Project Manager** under **Analysis**, right-click **Setup1** and select **Analyze**.
2. Right-click on **Setup1** again and select **Residual** to open the **Solutions** dialog box, where you can view the solution residuals as they are updated with each iteration.

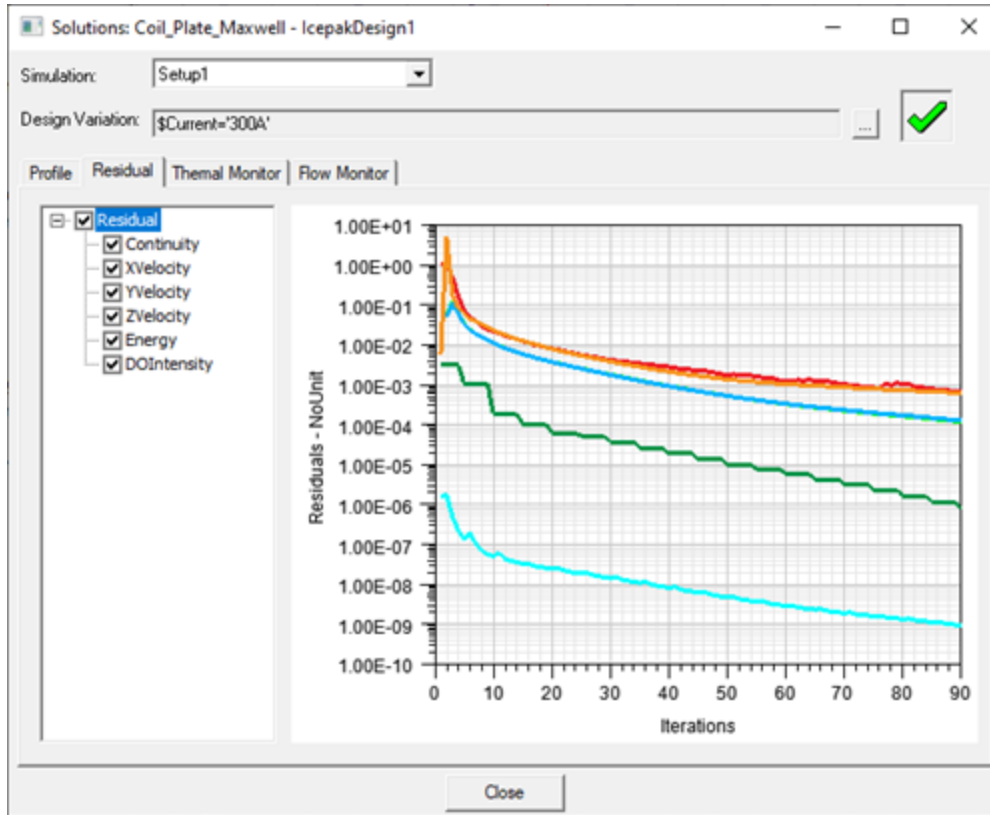

Figure 3-19: Solutions Dialog Box - Residual tab

3. Click the **Thermal Monitor** tab and review the monitor data.

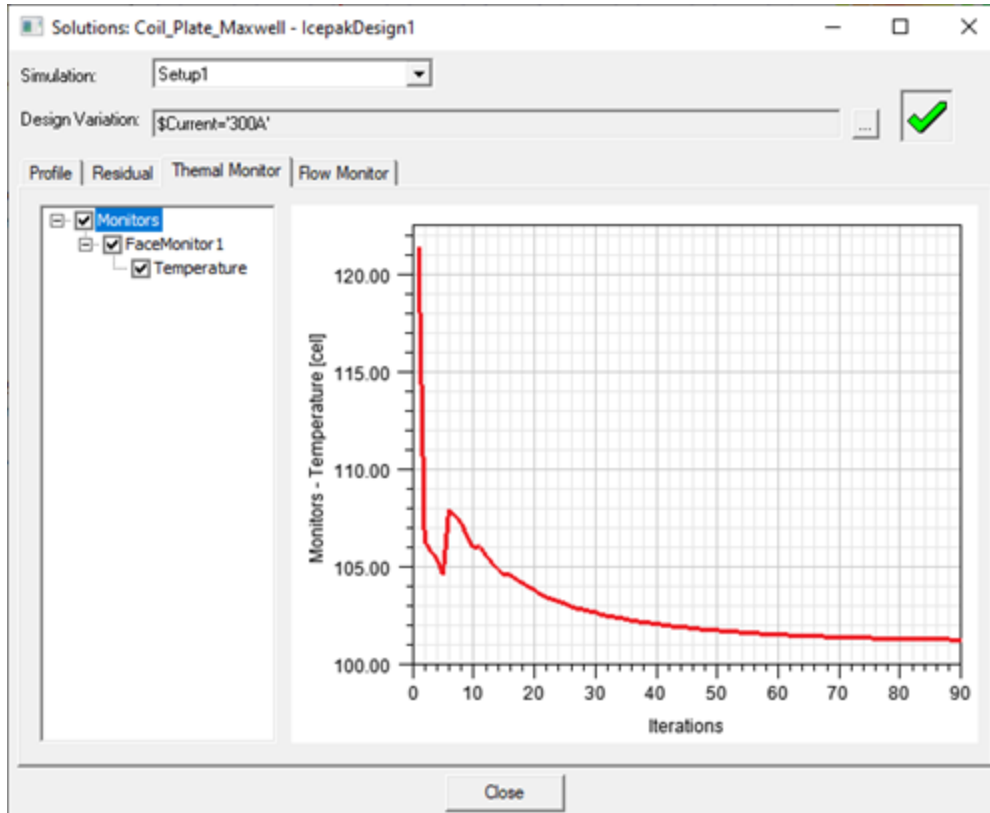

Figure 3-20: Solutions Dialog Box - Thermal Monitor tab

4. Click the **Profile** tab and review the EM loss data.

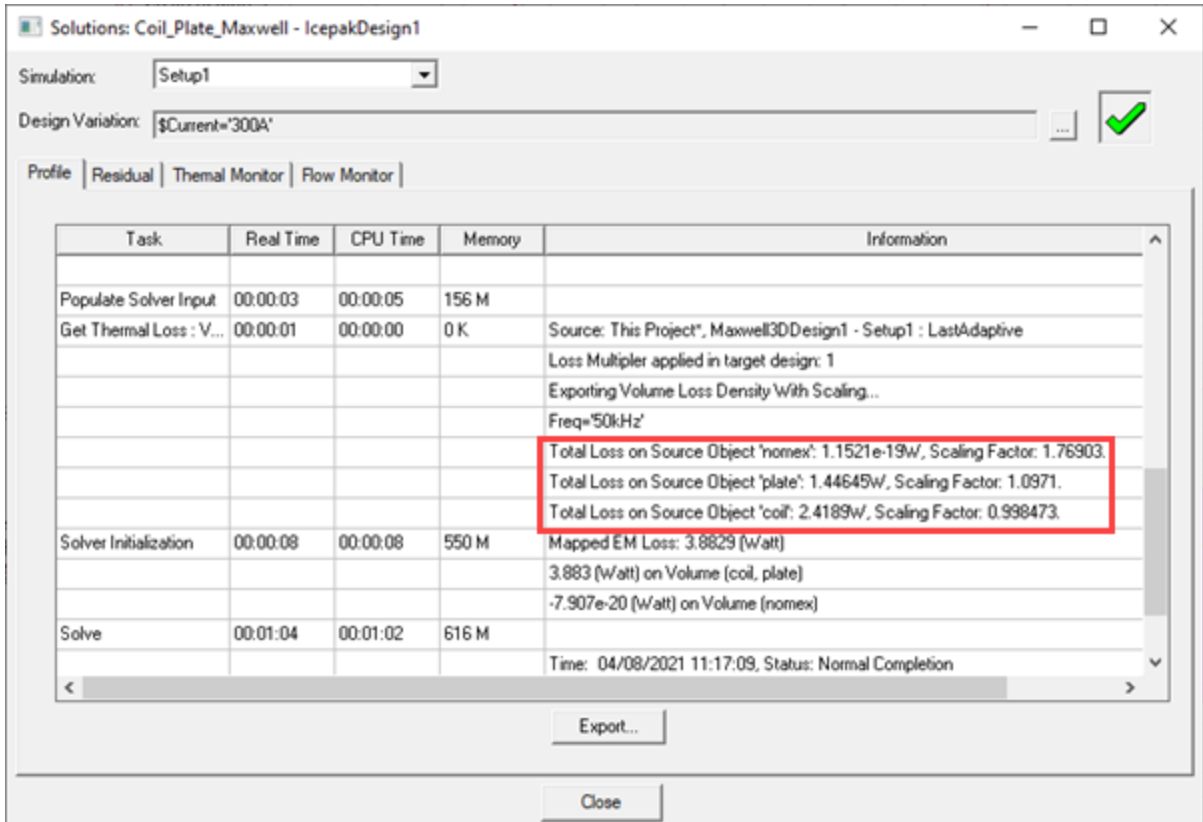

Figure 3-21: Solutions Dialog Box - Profile tab

5. Click **Close**.

# 4 - Postprocess the Icepak Simulation

This chapter contains the following topics:

- [Create Field Plots](#)
- [Create a Fields Summary](#)

## Create Field Plots

### Create a Temperature Field Plot

1. In the history tree, select *coil*, *plate*, and *nomex*.
2. Right-click on the selection and select **Plot Fields > Temperature > Temperature**.
3. In the **Create Field Plot** dialog box, retain the default selections under **Quantity** and **In Volume**.
4. Select the **Plot on surface only** check box.
5. Click **Done**.
6. Right-click on the **Temperature** legend and select **Modify**.
7. On the **Scale** tab under **Number Format**, select **Decimal** for **Type** and enter 6 for **Width**.
8. Click **Set as default** and then **Close**.

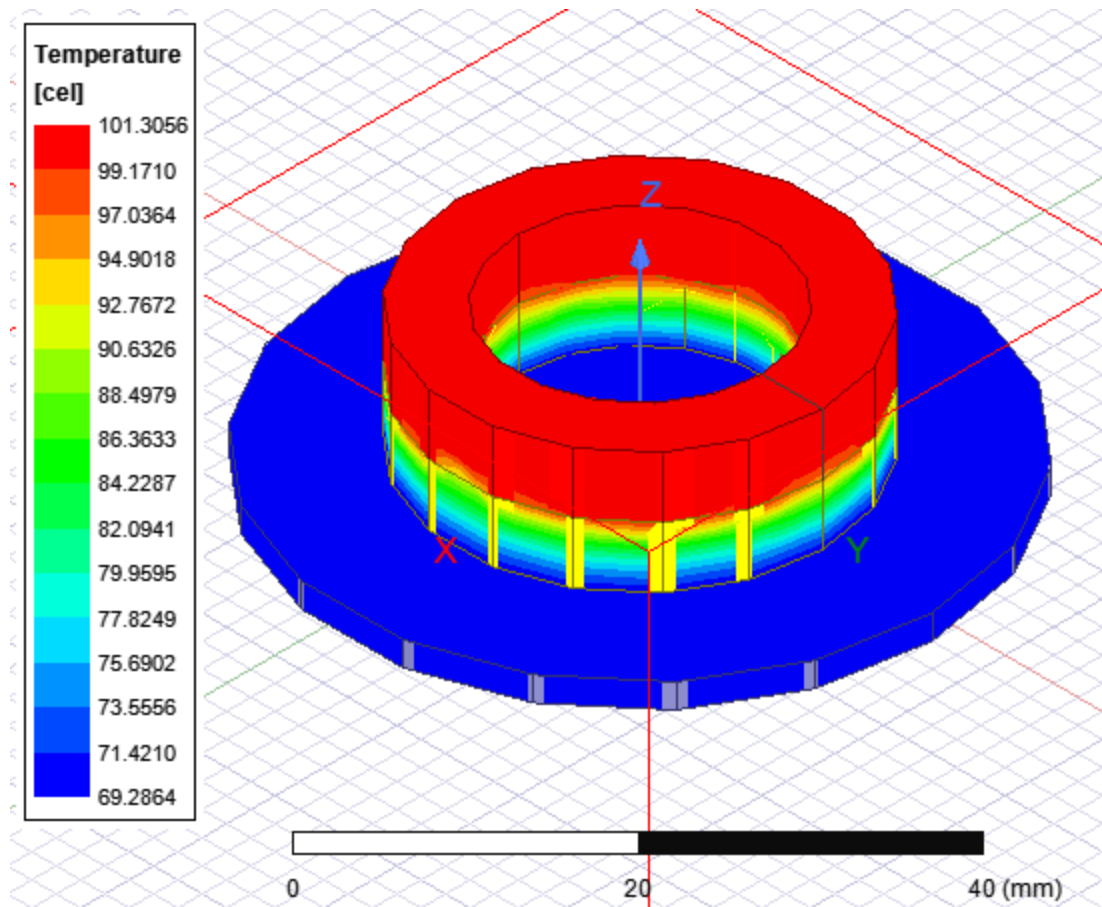



Figure 4-1: Temperature Field Plot

## Create a Plane

In order to display velocity on a plane cut, you must first create a plane. The plane will be in the middle of the model in the X direction.

1. On the **View** ribbon, click the **Isometric** orientation button  from the **Orient** drop-down list.
2. On the **Draw** ribbon, click the **Draw Plane** button .
3. In the **3D Modeler**, hover the cursor over the center of the model along with X plane.

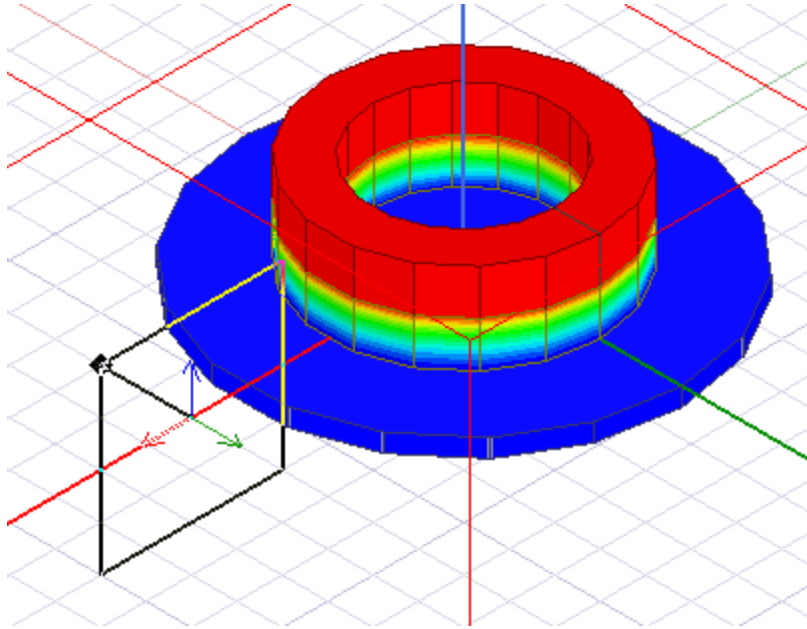

Figure 4-2: Plane creation

4. Hold **Y**, move the cursor up along the Y plane and click. The new plane displayed under **Planes** in the history tree.

## Create a Velocity Vector Plot

1. In the history tree, expand **Planes** and select the plane you created.
2. In the **3D Modeler** window, right-click and select **Plot Fields>Velocity>Velocity Vectors**.
3. In the **Create Field Plot** dialog box, retain the default selection of **Velocity Vectors** under **Quantity** and click **Done**. Velocity vectors are displayed on the plane.

**Note:** Click and drag the **Velocity** colorkey to also display the **Temperature** colorkey.

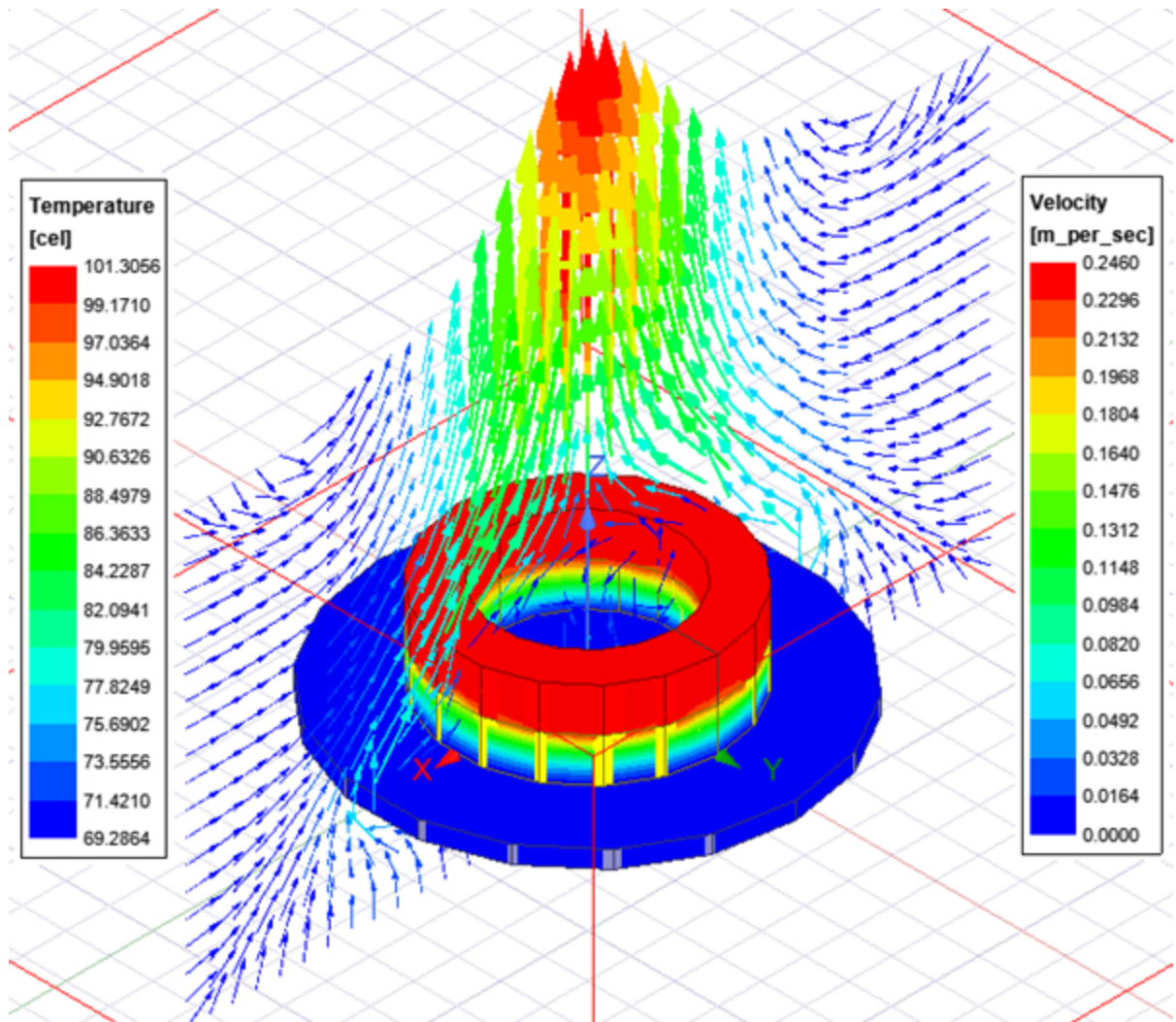
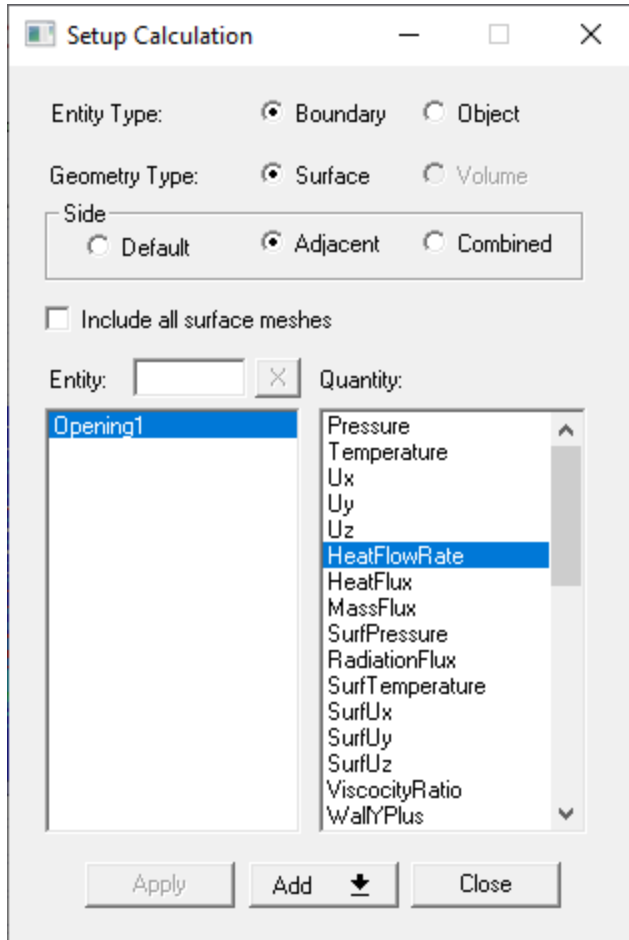

Figure 4-3: Velocity vectors on a plane

## Create a Fields Summary

Verify the energy balance using the Fields Summary report. The mapped loss is the only source of heat for the model. For a well converged solution, the heat dissipated from the system should be very close to the heat generated in the system.

1. On the **Results** ribbon, click **Create Fields Summary**.
2. In the **Setup Calculation** dialog box under **Entity**, select **Opening1**.
3. Under **Quantity**, select **HeatFlowRate**.
4. Under **Side**, select **Adjacent**.



**Figure 4-4: Setup Calculation**

5. Click the **Add** drop-down button and select **Add as a Single Calculation**.

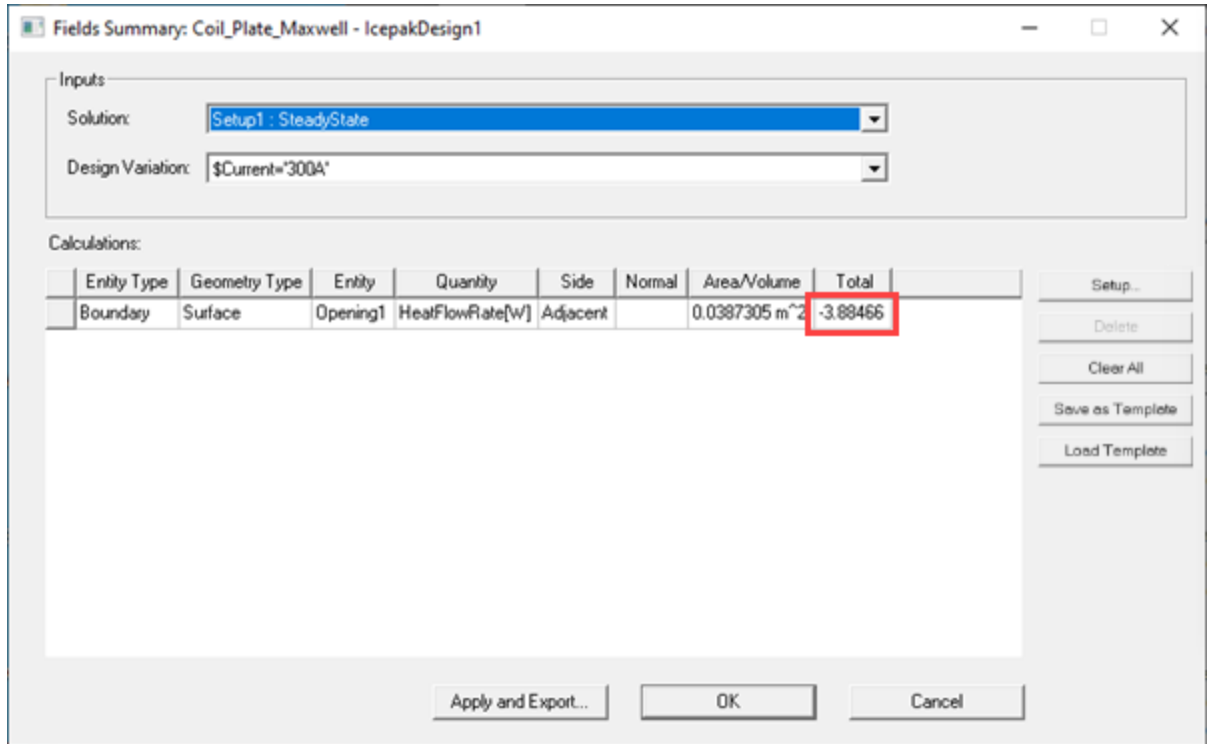

Figure 4-5: Fields Summary